

POS.	DESCRIPCION / DESCRIPTION	GJL 250	CF8M
1	CUERPO / BODY	GJL 250	CF8M
2	TAJADERA / KNIFE	AISI-304	AISI-316
3	ASIENTO / GUIDE	RCH 1000	RCH 1000
4	PRENSAESTOPAS / PACKING GLAND	GJS 500	CF8M
5	EMPAQUETADURA / PACKING	SYNT + PTFE	SYNT + PTFE
6	JUNTA / JOINT	EPDM	EPDM
7	SOPORTE / SUPPORT	S275JR	S275JR
8	ESPARRAGO / STUD	F-111 ZINC	AISI-316
9	ARANDELA / WASHER	ST ZINC	A-4
10	TUERCA AUTOBLOCANTE / SELF-LOCKING NUT	5.6 ZINC	A-4
11	TORNILLO / SCREW	5.6 ZINC	A-2
12	ARANDELA / WASHER	ST ZINC	A-2
13 *	CIERRE / SEAT	EPDM	EPDM
14 *	ANILLO / SOCKET	AISI-316	AISI-316

* → Estos elementos son opcionales
These elements are optional

OBSERVACIONES: Otros materiales bajo consulta.
NOTE: Other materials under request.



C/ Chile nº 10, Oficina 13
28290 Las Rozas (Madrid)
Tel: 91 630 30 95 - Fax: 91 630 36 92
info@induvalma.es
www.induvalma.es

VALVULAS DE GUILLOTINA Serie-A

PROGRAMA DE FABRICACION

KNIFE GATE VALVES A-Series

FABRICATION RANGE



- UTILIZACIÓN:

Válvula de tajadera unidireccional para líquidos cargados con sólidos hasta una concentración máxima de un 4%.

Aplicación principal: tubería en línea, entre bridas.

- UTILIZATION:

Unidirectional knife gate valve for liquids products mixed with solids until 4%

Main application: pipe in line, between flanges.



GESTION DE LA CALIDAD CERTIFICADA

QUALITY MANAGEMENT CERTIFIED



ACTUADORES / ACTUATORS

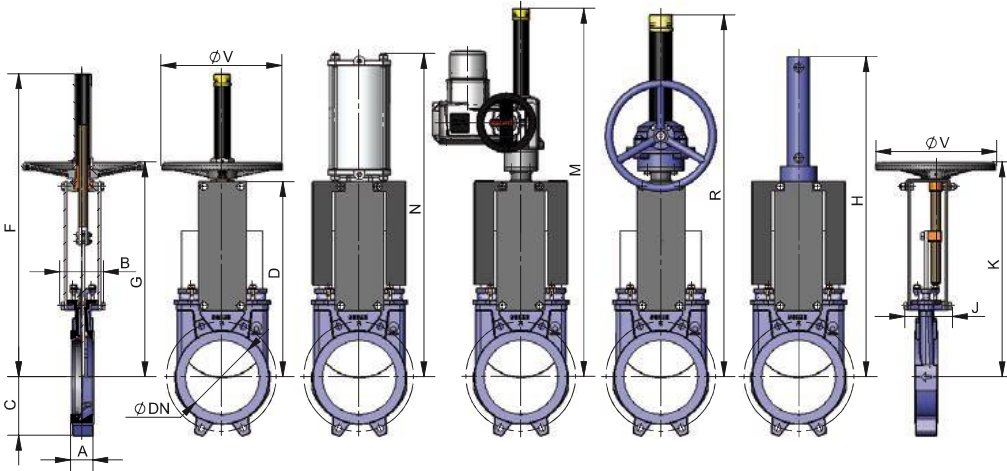

DIMENSIONES / DIMENSIONS													
DN	A	B	C	D	F	G	ØV	N	M	R	H	J	K
50	40	91	61	241	410	280	225	416	581	540	457	101	277
65	40	91	68	268	437	308	225	456	607	566	500	101	304
80	50	91	91	294	463	333	225	498	632	592	560	101	330
100	50	91	104	334	503	373	225	562	672	632	620	101	370
125	50	101	118	367	586	407	225	636	705	665	683	111	402
150	60	101	130	419	638	458	225	717	757	717	755	111	454
200	60	118	159	525	816	578	325	874	988	942	926	128	578
250	70	118	196	626	1017	679	325	1036	1089	1043	1077	128	679
300	70	118	230	726	1117	779	380	1182	1190	1194	1246	128	779
350	96	290	254	797	1337	906	450	1381	1302	1335	1376	305	860
400	100	290	287	903	1443	1012	450	1530	1458	1441	1532	305	981
450	106	290	304	989	1629	1098	450	1676	1754	1677	1707	305	1067
500	110	290	340	1101	1741	1210	450	1839	1866	1789	1869	305	1179
600	110	290	398	1307	2047	1416	450	2146	2073	2045	2176	305	1386
700	110	320	453	1506	---	---	---	2481	2391	2401	2525	---	---
800	110	320	503	1720	---	---	---	2798	2705	2715	2839	---	---
900	110	320	583	1953	---	---	---	3167	3033	3043	3172	---	---
1000	110	320	613	2137	---	---	---	3451	3328	3351	3496	---	---
1200	150	340	728	2616	---	---	---	4133	4047	4042	4175	---	---

OBSERVACIONES: Tamaños mayores bajo consulta. / NOTE: Bigger sizes under request.
 Cotas y dibujos sin compromiso. CMO S.L. se reserva, en cualquier momento, el derecho de modificarlos a discreción y sin previo aviso.
 Dimensions and drawings without obligation. CMO S.L. reserves, at any moment, the right of their modification at its own discretion and without any previous notice.

● → Agujeros ciegos / Tapped holes ○ → Agujeros pasantes / Through holes

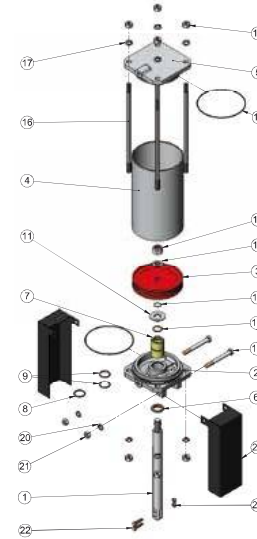

NEUMATICO / PNEUMATIC		
POS.	DESCRIPCION / DESCRIPTION	MATERIAL
1	VASTAGO / STEM	AISI-304
2	TAPA SOPORTE / CYLINDER HEAD Ø CAMISA / CYLINDER > Ø200 →	ALUMINIO / ALUMINIUM GJS 400
3	EMBOLO / PISTON	S275JR + EPDM
4	CAMISA / CYLINDER TUBE	ALUMINIO / ALUMINIUM
5	TAPA SUPERIOR / CYLINDER CAP Ø CAMISA / CYLINDER > Ø200 →	ALUMINIO / ALUMINIUM GJS 400
6	RASCADOR / SCRAPER	NITRILO / NITRILE
7	CASQUILLO / SOCKET	NYLON
8	ANILLO TORICO EXT. / OUTSIDE O-RING	NITRILO / NITRILE
9	ANILLO TORICO INT. / INSIDE O-RING	NITRILO / NITRILE
10	CIR-CLIP	ACERO / STEEL
11	ARANDELA / WASHER	ST ZINC
12	ANILLO TORICO / O-RING	NITRILO / NITRILE
13	ARANDELA / WASHER	ST ZINC
14	TUERCA AUTOBLOCANTE / SELF-LOCKING NUT	5,6 ZINC
15	ANILLO TORICO / O-RING	NITRILO / NITRILE
16	TIRANTES / TIE ROD	F-114 ZINC
17	ARANDELA / WASHER	ST ZINC
18	TUERCA / NUT	5,6 ZINC
19	TORNILLO / SCREW	5,6 ZINC
20	ARANDELA / WASHER	ST ZINC
21	TUERCA / NUT	5,6 ZINC
22	TORNILLO / SCREW	A-2
23	TUERCA AUTOBLOCANTE / SELF-LOCKING NUT	A-2
24	PROTECCION / PROTECTION	S275JR

HIDRAULICO / HYDRAULIC



VOLANTE / HANDWHEEL		
POS.	DESCRIPCION / DESCRIPTION	MATERIAL
1	HUSILLO / SPINDLE	AISI-303
2	PUENTE / YOKE	GJL 250
3	TUERCA HUSILLO / SPINDLE NUT	BRONCE / BRONZE
4	TUERCA TOPE / BUTT NUT	F-111
5	VOLANTE / HANDWHEEL	GJS 400
6	TUERCA CAPERUZA / HOOD NUT	5,6 ZINC
7	CAPERUZA / HOOD	ST-37
8	TAPON PROTECCION / PLUG PROTECTION	HD-500
9	ENGRASADOR / GREASER	ACERO / STEEL
10	TORNILLO / SCREW	5,6 ZINC
11	ARANDELA / WASHER	ST ZINC
12	TUERCA / NUT	5,6 ZINC
13	PRISIONERO / SETSCREW	ACERO / STEEL
14	TORNILLO / SCREW	A-2
15	TUERCA AUTOBLOCANTE / SELF-LOCKING NUT	A-2
16*	FUELLE PROTECTOR / PROTECTOR BELLOW	CAUCHO ANTIABRASIVO / ANTIABRASIVE RUBBER

* → Estos elementos son opcionales. / These elements are optional.

MOTOR / MOTOR

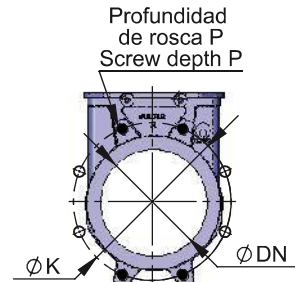

DN	ΔP Kg/Cm ²	TALADRADO DE BRIDAS / BORING JOINT									
		PN-10				ASA-150					
		●	○	M Métrico	P	ØK	●	○	R UNC	P	ØK
50	10	4	-	M 16	10	125	4	-	5/8"	10	120,6
65	10	4	-	M 16	10	145	4	-	5/8"	10	139,7
80	10	4	4	M 16	12	160	4	-	5/8"	12	152,4
100	10	4	4	M 16	12	180	4	4	5/8"	12	190,5
125	10	4	4	M 16	12	210	4	4	3/4"	12	215,9
150	8	4	4	M 20	17	240	4	4	3/4"	17	241,3
200	7	4	4	M 20	16	295	4	4	3/4"	16	298,4
250	5	8	4	M 20	19	350	8	4	7/8"	19	361,9
300	5	8	4	M 20	19	400	8	4	7/8"	19	431,8
350	4	12	4	M 20	28	460	8	4	1"	28	476,2
400	4	12	4	M 24	28	515	12	4	1"	28	539,7
450	3	16	4	M 24	28	565	12	4	1 1/8"	28	577,8
500	3	16	4	M 24	34	620	16	4	1 1/8"	34	635
600	3	16	4	M 27	26	725	16	4	1 1/8"	26	749,3
700	3	20	4	M 27	25	840	20	4	1 1/8"	25	863,6
800	3	20	4	M 30	22	950	24	4	1 1/2"	22	977,9
900	3	24	4	M 30	21	1050	28	4	1 1/2"	21	1085,9
1000	3	24	4	M 33	21	1160	32	4	1 1/2"	21	1200,2
1200	3	28	4	M 36	30	1380	40	4	1 1/2"	30	1422,4

OBSERVACIONES: Tamaños mayores bajo consulta. / NOTE: Bigger sizes under request.

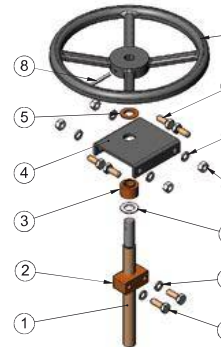

VOLANTE HUSILLO NO ASCENDENTE / NO-RISING STEM HANDWHEEL		
POS.	DESCRIPCION / DESCRIPTION	MATERIAL
1	HUSILLO / SPINDLE	AISI-303
2	TUERCA HUSILLO / SPINDLE NUT	BRONCE / BRONZE
3	CASQUILLO / SOCKET	BRONCE / BRONZE
4	PUENTE / YOKE	S275JR
5	CASQUILLO / SOCKET	BRONCE / BRONZE
6	ARANDELA / WASHER	ST ZINC
7	VOLANTE / HANDWHEEL	GJS 400
8	PASADOR / PIN	ACERO / STEEL
9	TORNILLO / SCREW	5,6 ZINC
10	ARANDELA / WASHER	ST ZINC
11	TUERCA / NUT	5,6 ZINC
12	ARANDELA / WASHER	A-2
13	TORNILLO / SCREW	A-2

REDUCTOR / SPUR GEAR

